

SEAL TYPE	CONTACT SIZE	MIN. INSUL. OD [mm]	MAX. INSUL. OD [mm]	WIRE RANGE [mm ²] REF ONLY
6	16	.100 [2.540]	.134 [3.404]	14-20 AWG [2.0-.50]
E	16	.053 [1.346]	.120 [3.048]	14-20 AWG [2.0-.50]

REV D DRC12-40PB*

REVISIONS			
SYM	DESCRIPTION	DATE	APPROVED
A	REVISED PER E.O. P17701	4-4-02	R.D.R.
B	REVISED PER E.O. P18662	8-26-04	R.D.R.
C	REVISED PER E.O. P19093	11-4-05	R.D.R.
D	REVISED PER E.O. P21119	10-28-11	RDR

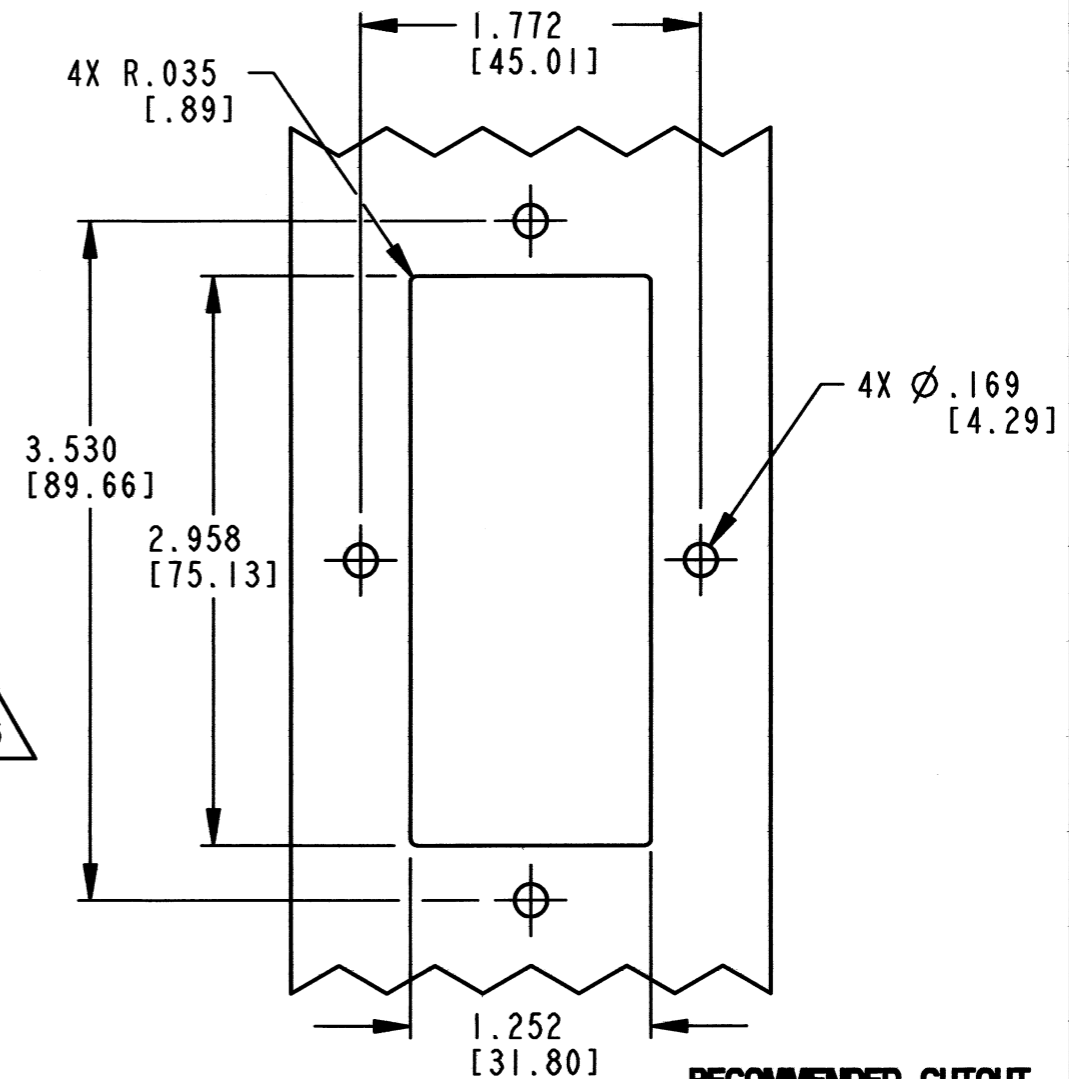
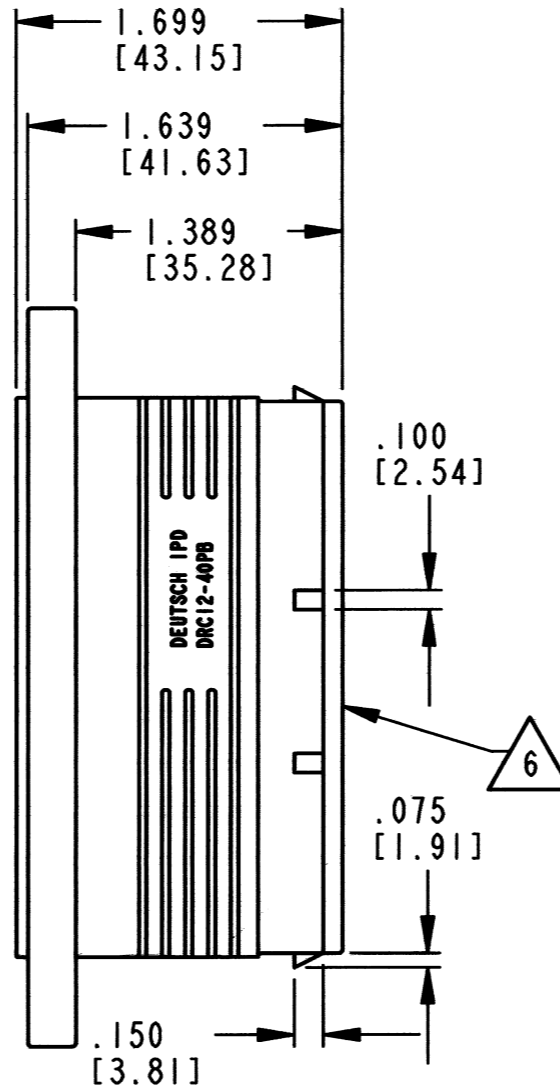
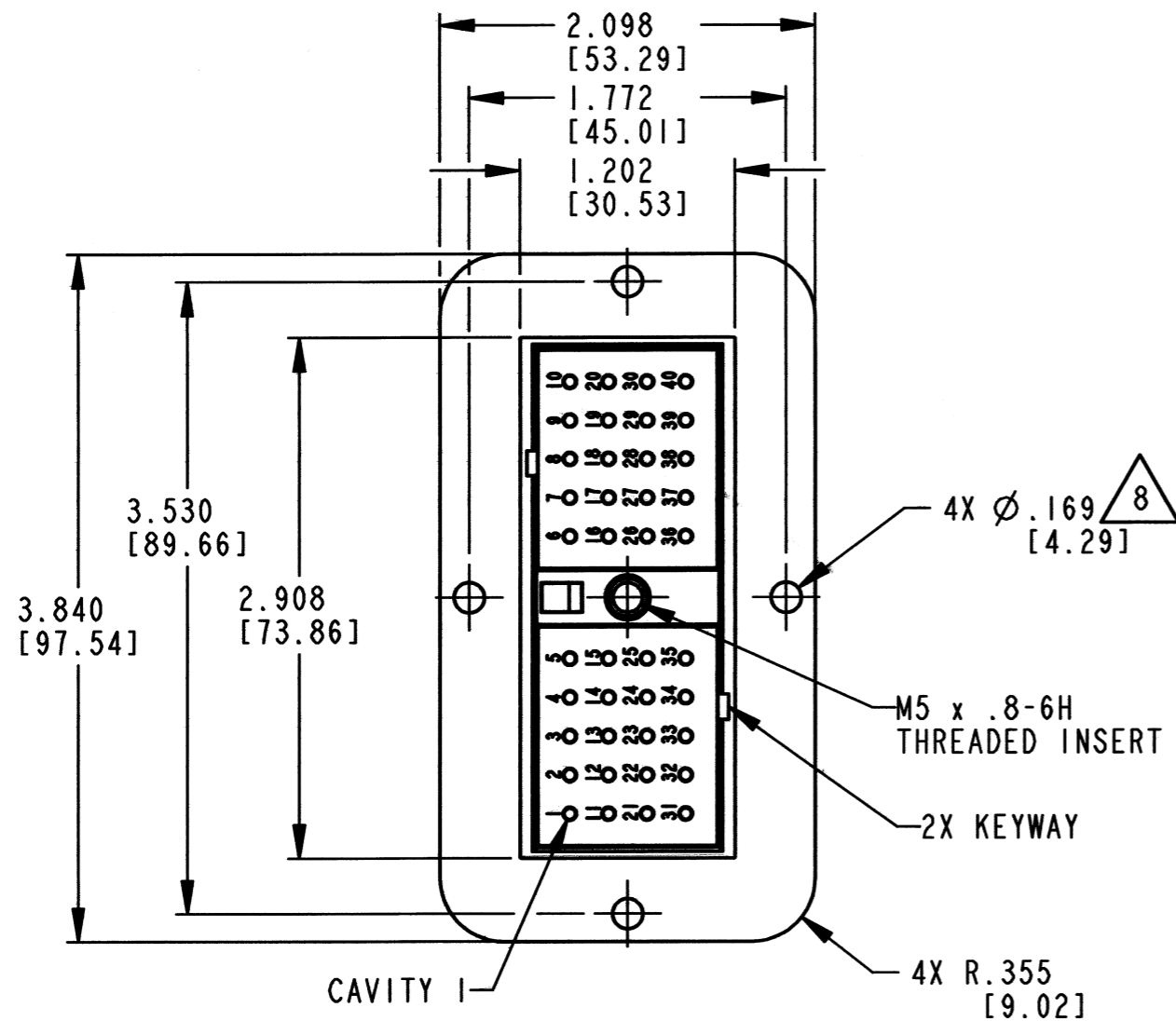

5. THIS RECEPTACLE MATES WITH DRC16-40S-****; DRC18-40SB-**** PLUGS. (****= ALL MODIFICATIONS) CONSULT FACTORY FOR MODS.
4. FOR CONTACT AND WIRE PERFORMANCE AND APPLICATION CHARACTERISTICS, SEE DRAWING 0425-015-0000.
3. RECEPTACLE IS SUPPLIED WITH DUST CAP (NOT SHOWN).
2. DIMENSION TOLERANCE: ±.025 [.635]; PANEL CUTOUT: ±.010 [.25].
1. DIMENSIONS ARE IN INCHES [mm].

NOTES:

8 RECOMMENDED SCREW: 8-32 [M4]. TORQUE: 20-25 IN-LB [2.26-2.82 Nm].

7 MATERIAL: HOUSING: PLASTIC; GROMMET: RUBBER; INSERT: STEEL.

6. WHEN * = E: BLUE STRIP ON WELD CAP IDENTIFIES "E" WIRE SEAL.

SIGNATURE & DATE	
DR	D. MEYER 08/09/99
CHK	D. Hasibuan 9/26/11
PE	D. Hasibuan 9/26/11
APPD	D. Meyer 10/27/11
SCALE	NONE [W]

RECEPTACLE, FLANGED
40 SIZE 16
DRC SERIES
KEY ARRANGEMENT -B-

ENVELOPE

MATERIAL CODE	
EP	3850 INDUSTRIAL AVE. HEMET, CA 92545
DEUTSCH INDUSTRIAL	
B DRC12-40PB*	
DWG SIZE	CODE 11139 SHEET OF